

Ventomat®

Hochleistungsventilatoren für die Heutrocknung



Ventomat Radialventilatoren zeichnen sich aus durch:

- extrem hohe Wirkungsgrade
- auffallende Laufruhe
- günstige Preise
- grosse Luft- und Druckleistung
- grosse Modellreihe
- Schweizerfabrikat

FAT	Ventomat	Grösse		mbar	2	3	4	5	6	7	8	9	10	11	12	13	14	16	18	max. Druck	Lärm	
Test-Nr.	Typ	KW	PS	mmWs	20	30	40	50	60	70	80	90	100	110	120	130	140	160	180	mbar	dB(A)	
1084 T	R-2 K	4.0	5.5	m ³ /s KW %	9.2 4.6 40	8.4 4.7 53	7.3 4.8 61	6.0 4.7 64	4.1 4.2 58												6.3	63/65
1084	R-2 K	5.5	7.5	m ³ /s KW %	10.6 6.1 35	9.8 6.4 46	9.0 6.4 56	8.0 6.6 61	6.9 6.5 64	5.4 6.1 62											7.7	65/67
1085	R-2 K	7.5	10.0	m ³ /s KW %	12.3 8.3 30	11.7 8.7 40	11.1 9.1 49	10.3 9.1 57	9.4 9.2 61	8.5 9.2 64	7.4 9.1 65	6.0 8.7 62									9.9	69/71
1085 H	R-2 K	10.0	13.5	m ³ /s KW %	13.5 10.3 26	12.9 10.9 36	12.4 11.2 44	11.8 11.7 51	11.0 11.5 57	10.2 11.7 61	9.3 11.7 64	8.3 11.6 65	7.3 11.3 64	4.1 8.4 53							11.6	71/73
1515 T	R-3 L	4.0	5.5	m ³ /s KW %	9.1 3.8 48	8.2 4.3 57	7.3 4.7 62	6.2 5.0 62	4.8 5.0 58	1.8 3.7 33											7.1	62/64
1515 K	R-3 L	5.5	7.5	m ³ /s KW %	10.1 4.5 44	9.3 5.2 54	8.4 5.7 59	7.5 6.1 62	6.5 6.3 62	5.2 6.3 58	2.8 5.3 42										8.3	64/66
1516 U	R-3 L	7.5	10.0	m ³ /s KW %	11.6 5.9 39	11.0 6.6 50	10.2 7.3 57	9.5 7.7 61	8.7 8.2 64	7.9 8.6 64	6.9 8.8 63	5.6 8.5 58	3.6 7.5 47								10.4	67/69
1516 T	R-3 L	9.5	12.6	m ³ /s KW %	12.7 7.2 36	12.1 8.0 46	11.6 8.7 53	10.8 9.4 58	10.1 9.9 61	9.4 10.4 63	8.7 10.8 64	7.6 11.1 64	6.8 11.0 61	5.4 10.6 55	2.2 8.1 33						12.2	69/71
1516 K	R-3 L	11.0	15.0	m ³ /s KW %	13.2 7.8 34	12.7 8.6 44	12.1 9.4 51	11.5 10.2 56	10.8 10.7 60	10.1 11.3 63	9.4 11.7 64	8.6 12.1 64	7.7 12.2 62	6.6 12.1 60	5.3 11.8 54	1.3 7.6 23					13.0	70/72
1069 T	R-3 K	5.5	7.5	m ³ /s KW %	12.2 5.8 42	11.0 6.2 54	9.7 6.2 62	8.3 6.3 65	6.5 6.1 64	3.7 5.2 50											7.4	60/62
1069	R-3 K	7.5	10.0	m ³ /s KW %	14.3 8.0 36	13.3 8.5 47	12.3 8.9 55	11.0 8.9 62	9.8 9.1 65	8.5 9.1 65	6.7 8.6 62	3.5 7.1 44									9.4	63/65
928 T	R-3 K	10.0	13.5	m ³ /s KW %	16.4 10.0 33	15.4 10.8 43	14.4 11.3 51	13.5 11.7 58	12.2 11.8 62	11.1 11.9 65	10.0 11.9 67	8.7 11.9 66	7.0 11.3 62	4.0 9.4 55							11.5	66/68
928	R-3 K	11.0	15.0	m ³ /s KW %	17.1 10.9 31	16.1 11.8 41	15.1 12.2 49	14.2 12.7 56	13.0 12.9 60	11.9 13.0 64	10.9 13.1 67	9.1 12.9 66	8.1 12.6 64	6.0 11.6 57							12.2	67/69
1926K	R-3 K	15.0	20.0	m ³ /s KW %	18.5 13.8 32	17.7 14.4 38	17.0 15.1 44	16.2 15.6 49	15.3 16.1 54	14.5 16.6 58	13.5 16.9 62	12.5 17.1 65	11.4 17.2 66	10.2 17.1 67	8.9 16.7 65	7.3 15.9 61	5.2 14.4 51				14.6	69/71
1925K	R-3 K	18.5	25.0	m ³ /s KW %	20.1 16.7 28	19.4 17.4 34	18.7 18.1 39	18.0 18.7 45	17.3 19.3 50	16.5 19.8 54	15.7 20.3 58	14.8 20.6 62	13.9 20.9 65	13.0 21.1 67	11.9 21.1 68	10.7 20.9 68	9.4 20.4 67	5.9 18.0 53			16.8	70/74
1924K	R-3 K	22.0	30.0	m ³ /s KW %	21.5 19.9 28	20.9 20.6 33	20.3 21.3 38	19.7 22.0 42	19.0 22.6 47	18.3 23.2 51	17.6 23.7 55	16.9 24.2 58	16.1 24.6 62	15.3 24.9 64	14.4 25.1 67	13.5 25.3 68	12.5 25.2 69	10.1 24.6 68	6.9 22.3 57		19.3	73/77

doppelseitig saugend

Leistungstabelle für Hochleistungsventilatoren Ventomat®

FAT	Ventomat	Grösse		mbar	2	3	4	5	6	7	8	9	10	11	12	13	14	16	18	max. Druck	Lärm
Test-Nr.	Typ	KW	PS	mmWs	20	30	40	50	60	70	80	90	100	110	120	130	140	160	180	mbar	dB(A)
1086 U	R-4 K	7.5	10.0	m ³ /s KW %	16.4 7.7 42	15.0 8.3 54	13.4 8.7 62	11.8 9.0 65	10.3 9.1 68	8.4 8.8 67										8.0	63/64
1086 T	R-4 K	10.0	13.5	m ³ /s KW %	18.7 10.1 37	17.4 10.8 48	16.1 11.4 57	14.6 11.8 62	13.1 12.1 65	11.8 12.2 68	10.3 12.0 68	6.6 10.5 56								9.7	65/66
1086	R-4 K	11.0	15.0	m ³ /s KW %	19.4 10.9 36	18.2 11.7 47	16.9 12.3 55	15.5 12.7 61	14.1 13.1 64	12.7 13.3 67	11.3 13.3 68	9.4 12.8 66	3.0 9.3 32							10.3	66/67
1086 H	R-4 K	15.0	20.0	m ³ /s KW %	22.0 14.5 30	20.9 15.3 41	19.8 16.1 49	18.6 16.8 55	17.3 17.2 61	16.1 17.7 64	14.8 18.0 66	13.5 18.1 67	12.2 17.9 67	10.6 17.5 66	5.2 13.8 44					12.6	68/69
1934	R-4 K	18.5	25.0	m ³ /s KW %	22.3 15.4 38	21.5 16.4 43	20.7 17.3 48	19.8 18.2 53	18.9 19.0 57	17.9 19.7 60	16.8 20.3 64	15.7 20.8 66	14.5 21.1 68	13.1 21.3 68	11.5 21.1 67	9.4 20.3 62	6.4 18.2 50			14.3	70/73
1935	R-4 K	22.0	30.0	m ³ /s KW %	23.3 16.9 40	22.5 17.9 45	21.7 18.8 49	20.9 19.7 53	20.0 20.5 57	19.1 21.3 60	18.2 22.0 63	17.1 22.6 66	16.0 23.1 68	14.8 23.4 69	13.4 23.5 69	11.8 23.2 68	9.9 22.5 63			15.4	76/79
1320 T	R-5 K	7.5	10.0	m ³ /s KW %	18.9 8.6 44	17.0 9.0 57	14.9 9.0 66	12.3 9.0 69	9.2 8.4 65	1.4 6.4 16										7.0	63/65
1320 K	R-5 K	10.0	13.5	m ³ /s KW %	20.8 10.5 40	19.2 11.0 52	17.4 11.3 61	15.2 11.3 67	12.8 11.1 69	9.7 10.4 65	3.9 8.5 37									8.1	64/66
1320	R-5 K	11.0	15.0	m ³ /s KW %	21.7 11.5 38	20.1 12.0 50	18.3 12.4 59	16.4 12.4 66	14.1 12.3 68	11.6 11.9 68	7.3 10.6 55									8.6	65/67
1320 H	R-5 K	15.0	20.0	m ³ /s KW %	25.3 16.5 33	24.0 17.0 42	22.6 17.5 52	21.0 18.1 58	19.4 18.0 65	17.4 18.1 68	15.3 17.9 69	12.8 17.2 67	9.6 16.4 60	3.4 13.0 30						11.1	68/70
1936	R-5 K	18.5	25.0	m ³ /s KW %	25.7 16.7 41	24.5 17.7 46	23.2 18.6 51	21.9 19.4 56	20.5 20.1 59	18.9 20.7 62	17.3 21.1 64	15.4 21.3 65	13.2 21.1 63	10.6 20.4 58	6.9 18.4 45					12.4	70/73
1937	R-5 K	22.0	30.0	m ³ /s KW %	28.0 19.9 37	26.9 20.9 42	25.8 21.8 47	24.6 22.6 52	23.4 23.4 57	22.0 24.1 61	20.6 24.7 64	19.0 25.1 66	17.3 25.3 67	15.4 25.3 67	13.1 24.9 64	10.1 23.6 56				13.9	70/73
1846T	R-6 K	11.0	15.0	m ³ /s KW %	22.3 10.3 45	20.8 11.3 53	19.0 12.1 60	17.1 12.7 65	14.8 13.2 68	11.8 13.1 66	6.7 11.5 47									8.1	63/65
1846	R-6 K	15.0	20.0	m ³ /s KW %	25.8 14.1 42	24.4 15.2 49	23.0 16.2 55	21.4 17.1 60	19.7 17.9 64	17.8 18.4 67	15.6 18.7 68	12.7 18.5 65	8.3 16.7 50							10.2	66/68
1847	R-6 K	18.5	25.0	m ³ /s KW %	28.0 16.8 42	26.8 18.0 48	25.5 19.2 53	24.1 20.2 58	22.7 21.2 62	21.1 22.0 65	19.3 22.6 67	17.2 23.0 68	14.7 22.9 66	11.3 21.8 59						11.6	66/70
1848	R-6 K	22.0	30.0	m ³ /s KW %	29.8 19.3 41	28.7 20.6 47	27.5 21.7 51	26.2 22.8 56	24.9 23.8 60	23.4 24.7 63	21.8 25.5 66	20.1 26.1 68	18.1 26.4 68	15.7 26.3 67	12.4 25.4 61					12.8	69/73

doppelseitig saugend

Leistungstabelle für Hochleistungsventilatoren Ventomat®

FAT	Ventomat	Grösse		mbar	2	3	4	5	6	7	8	9	10	11	12	13	14	16	18	max. Druck	Lärm	
Test-Nr.	Typ	KW	PS	mmWs	20	30	40	50	60	70	80	90	100	110	120	130	140	160	180	mbar	dB(A)	
529	SE	3.0	4.0	m ³ /s KW %	5.3 3.6 30	5.1 3.8 41	4.8 3.9 49	4.4 4.0 55	4.0 4.0 60	3.5 4.0 61	3.0 3.9 61	2.2 3.2 55									9.5	61/65
285	SE	4.0	5.5	m ³ /s KW %	5.8 4.3 27	5.6 4.4 38	5.3 4.5 46	4.8 4.5 53	4.4 4.6 58	3.9 4.5 60	3.3 4.3 62	2.7 4.0 59									9.6	69/73
1950	SE-B	5.5	7.5	m ³ /s KW %	5.0 4.2 22	4.8 4.4 31	4.7 4.7 38	4.5 4.9 45	4.3 5.1 51	4.2 5.3 55	4.0 5.5 59	3.8 5.7 61	3.6 5.9 62	3.4 6.0 63	3.1 6.1 62	2.9 6.1 61	2.6 6.1 58				15.8	68/69
1081	SE-2	3.0	4.0	m ³ /s KW %	5.5 3.3 33	5.2 3.5 45	4.9 3.6 54	4.5 3.8 59	4.1 3.9 63	3.6 3.9 64	3.0 3.8 64	2.3 3.5 62									9.6	65/70
1082	SE-2	4.0	5.5	m ³ /s KW %	6.3 4.3 29	6.0 4.5 40	5.7 4.6 49	5.4 4.7 58	4.9 4.6 63	4.5 4.7 66	4.0 4.7 68	3.5 4.1 67	2.0 3.1 54								10.1	67/69
530	SE-2	5.5	7.5	m ³ /s KW %	7.6 6.0 25	7.2 6.2 35	6.5 6.1 43	6.0 6.1 50	5.4 6.1 54	4.8 6.0 56	4.1 5.8 57	3.6 5.5 56	2.8 5.0 55								10.0	68/70
1951	SE-2B	7.5	10.0	m ³ /s KW %	6.4 5.5 45	6.3 5.9 48	6.1 6.2 50	5.9 6.5 53	5.7 6.8 55	5.5 7.1 57	5.3 7.3 59	5.1 7.5 60	4.8 7.8 62	4.6 7.9 63	4.3 8.1 63	4.0 8.2 63	3.6 8.2 62	2.6 7.7 55			16.4	70/74
1933	RE-2-160-4p	5.5	7.5	m ³ /s KW %	5.6 4.6 25	5.4 4.8 32	5.2 5 39	4.9 5.2 46	4.7 5.3 51	4.4 5.4 56	4.1 5.5 60	3.8 5.6 63	3.4 5.6 64	2.9 5.5 61	2.3 5.2 53						12.2	68/71
1083	SE-3	5.5	7.5	m ³ /s KW %	9.1 5.0 37	8.5 5.5 47	7.9 5.9 54	7.3 6.2 59	6.5 6.3 62	5.9 6.5 63	5.2 6.6 64	4.4 6.4 59	1.5 4.4 33								10.1	65/68
1923	SE-3K	5.5	7.5	m ³ /s KW %	8.3 4.5 39	7.9 4.9 45	7.5 5.3 51	7.0 5.6 57	6.5 5.9 61	5.9 6.2 65	5.3 6.3 67	4.7 6.4 67	3.9 6.2 65	2.9 5.8 57	1.5 4.6 37						12.1	63/67
1772	SE-3	7.5	10.0	m ³ /s KW %	9.8 5.6 40	9.3 6.0 47	8.8 6.4 53	8.3 6.8 58	7.7 7.1 63	7.0 7.3 66	6.3 7.4 68	5.6 7.4 69	4.7 7.3 66	3.6 6.8 60	2.1 5.6 43						12.2	66/69
1849	SE-3G	7.5	10.0	m ³ /s KW %	9.2 5.8 32	8.9 6.3 39	8.5 6.7 45	8.1 7.1 51	7.6 7.4 56	7.2 7.7 61	6.7 8.0 65	6.1 8.1 68	5.5 8.2 69	4.7 8.1 68	3.8 7.6 63	2.3 6.3 47					13.1	68/74
1161	SE-4	7.5	10.0	m ³ /s KW %	11.0 6.4 34	10.5 7.1 45	9.9 7.7 52	9.3 8.1 57	8.6 8.4 62	7.8 8.5 65	7.2 8.7 66	6.5 8.8 66	5.9 8.8 65	4.8 8.4 61	3.2 6.5 41						12.3	66/70
1517	SE-4	11.0	15.0	m ³ /s KW %	12.8 9.5 27	12.4 10.3 36	11.9 10.9 43	11.4 11.6 49	10.9 12.1 54	10.4 12.5 58	9.9 12.8 62	9.2 12.7 65	8.4 12.7 66	7.5 12.7 67	6.8 12.5 66	5.5 11.7 62	3.3 9.0 51				14.1	71/74
1930	SE-4-300-6p	15.0	20.0	m ³ /s KW %	14.7 13.5 26	14.2 14.0 31	13.7 14.4 36	13.2 14.8 41	12.7 15.1 46	12.2 15.4 50	11.6 15.6 55	10.9 15.8 58	10.2 15.9 62	9.4 15.8 64	8.5 15.5 66	7.4 14.9 66	5.9 13.6 63				14.7	73/78
1922	RE-4-255-4p	18.5	25.0	m ³ /s KW %			14.4 17.6 32	14.0 18.0 37	13.5 18.5 41	13.0 18.8 45	12.6 19.2 48	12.0 19.5 52	11.5 19.7 55	10.9 19.8 57	10.3 19.8 60	9.5 19.7 62	8.8 19.5 63	6.8 18.0 62			17.5	76/81

einseitig saugend

Leistungstabelle für Hochleistungsventilatoren Ventomat®

Masse für doppelseitig saugende Ventilatoren

Typen: R-2K, R-3L, R-3K, R-4K, R-5K, R-6K

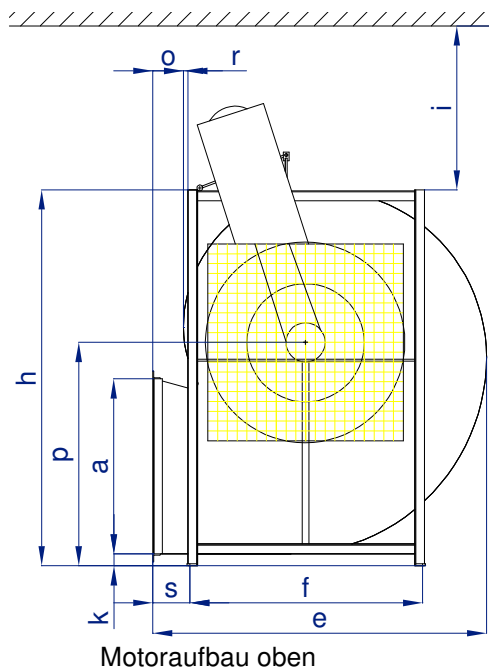
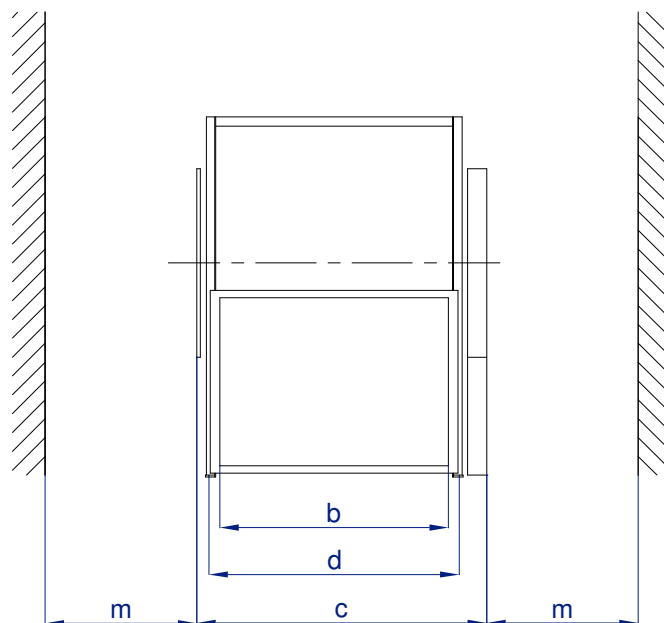
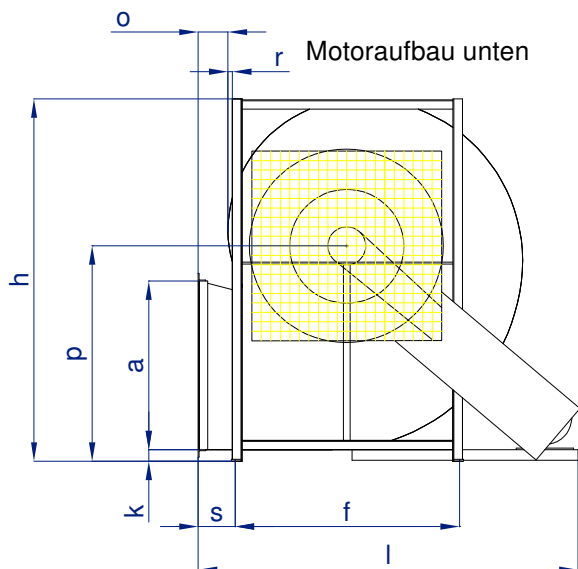

Ausblasöffnung nach unten

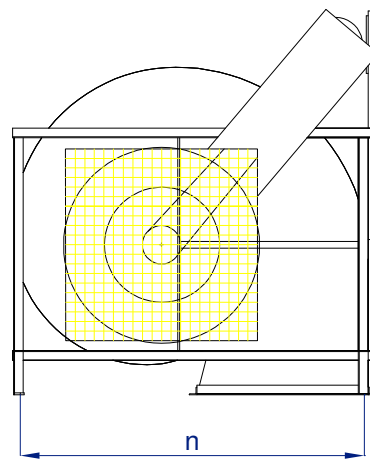

Typ	a [mm]	b [mm]	c [mm]	d [mm]	e [mm]	f [mm]	h [mm]	i [mm]	k [mm]	l [mm]	m [mm]	n [mm]	o [mm]	p [mm]	r [mm]	s [mm]	Gewicht ca. [kg]
R-2K	690	1210	1520	1325	1440	955	1730	500	60	1700	800	1655	90	1055	45	140	400
R-3L	890	1070	1390	1175	1710	1180	1930	500	60	2000	800	1800	150	1140	30	190	470
R-3K	890	1210	1530	1325	1710	1180	1930	500	60	2000	800	1800	150	1140	30	190	480
R-4K	1060	1210	1550	1325	1900	1180	2250	600	60	2000	800	2050	55	1330	100	170	650
R-5K	1150	1285	1625	1400	2040	1275	2590	600	60	2040	1000	2345	0	1565	115	140	720
R-6K	1220	1455	1800	1575	2040	1275	2600	600	60	2040	1000	2345	0	1565	115	140	850

Masse für einseitig saugende Ventilatoren

Typen: SE, SE-2, SE-3, SE-4

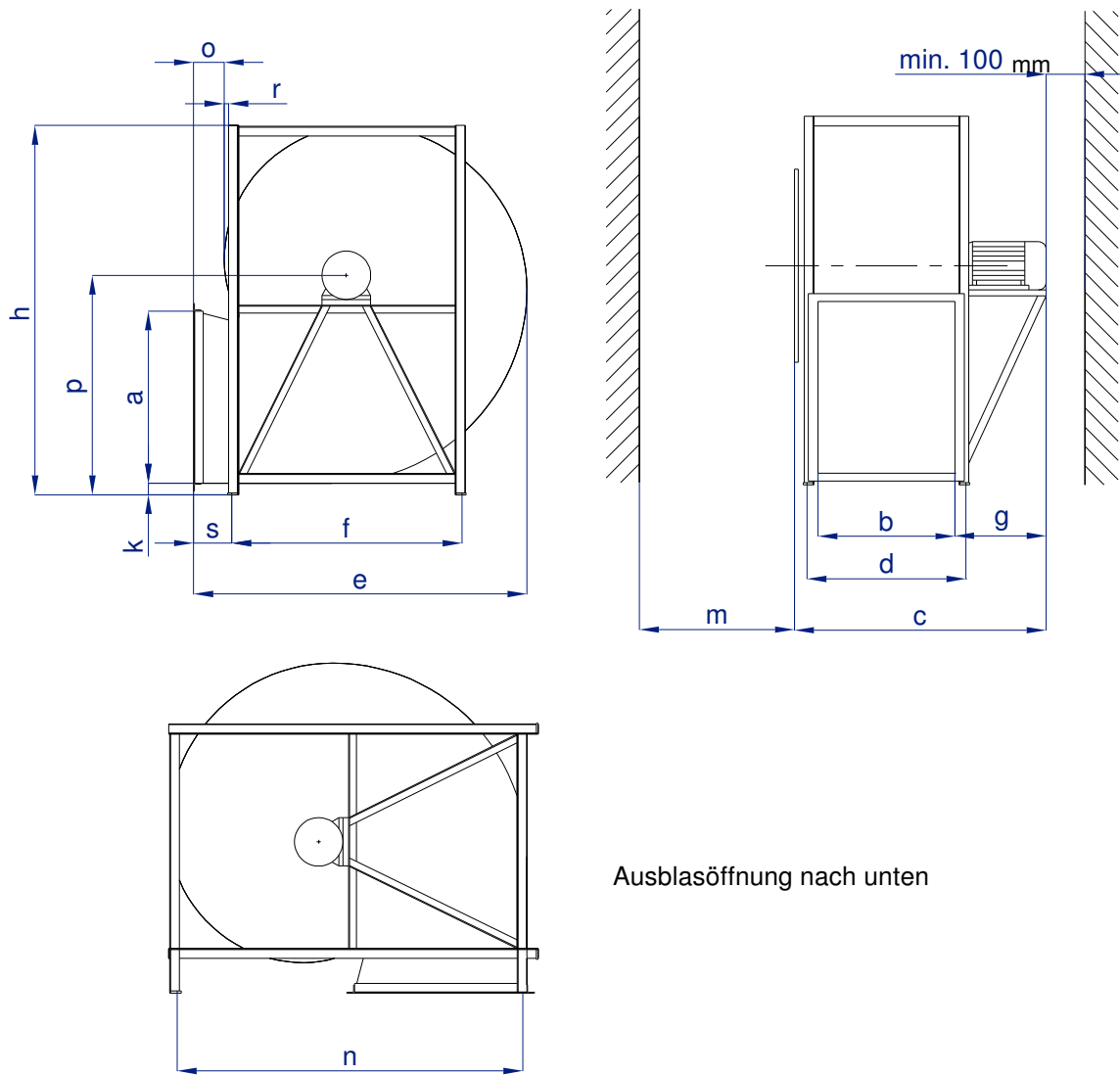

Typ	a [mm]	b [mm]	c [mm]	d [mm]	e [mm]	f [mm]	g [mm]	h [mm]	k [mm]	m [mm]	n [mm]	o [mm]	p [mm]	r [mm]	s [mm]	Gewicht ca. [kg]
SE SE-B	640	460	1030	570	1450	950	460	1740	60	600	1655	85	1045	45	140	260
SE-2 SE-2B	640	580	1150	695	1450	950	460	1740	60	800	1655	85	1045	45	140	270
SE-3 SE-3K SE-3G	970	710	1310	815	1710	1180	550	1930	60	800	1800	150	1140	30	185	380
SE-4	1060	710	1500	820	1900	1185	630	2240	60	900	2050	55	1330	100	170	420

Bestellhinweise für die Gehäusestellung und Aufbau des Motors

Für doppelseitig saugende Lüfter

0°- U

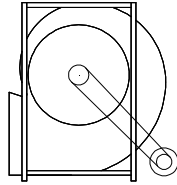

90°- U

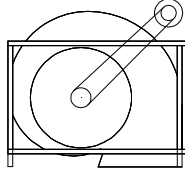

180°- U

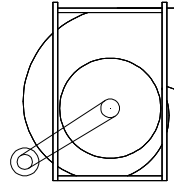

0°- O

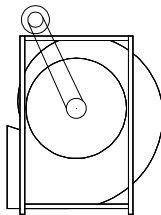

90°- O

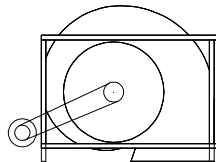

180°- O

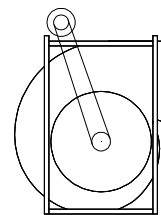

Ohne spezielle Angaben wird der Ventilator in Gehäusestellung 0° geliefert.
Der Motoraufbau erfolgt bei der Gehäusestellung 0° normalerweise in Ausblasrichtung
gesehen links.

Für einseitig saugende Lüfter

0°- L

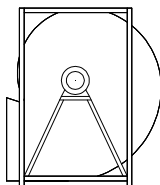

90°- L

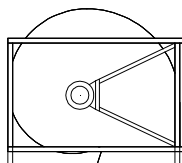

180°- L

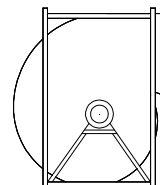

0°- R

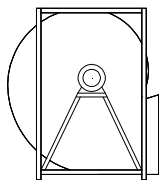

90°- R

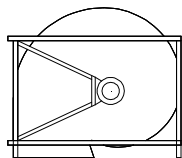

180°- R

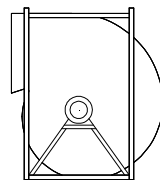

Ohne spezielle Angaben wird der Ventilator in Gehäusestellung 0° geliefert.
Der Motoraufbau erfolgt bei der Gehäusestellung 0°, in Ausblasrichtung gesehen auf Wunsch
links oder rechts.

Auswahltabelle für Ventomat® Heubelüftungsventilatoren

Stock- fläche [m ²]	Stockhöhe									
	3,5 m	4 m	4,5 m	5 m	5,5 m	6 m	6,5 m	7 m	7,5 m	8 m
35	529	529	529	529	529	529	529	529	1950	1950
40	529	529	529	529	529	529	529	529	1950	1950
45	529	529	1081	1081	285	285	1082	1082	1933	1933
50	285	285	285	285	1082	1082	1082	1082	1923	1923
55	1082	1082	1082	1082	530	530	530	530	1923	1923
60	530	530	530	530	530	530	1083	1083	1923	1923
65	530	530	530	530	1083	1083	1083	1083	1772	1772
70	1084 T	1084 T	1083	1083	1083	1083	1772	1772	1772	1772
75	1084 T	1515 T	1515 K	1515 K	1515 K	1772	1772	1772	1161	1161
80	1084 T	1084 T	1515 K	1772	1772	1516 U	1516 U	1161	1161	1161
85	1515 K	1515 K	1772	1772	1516 U	1516 U	1516 U	1161	1516T	1516T
90	1084	1084	1516 U	1516 U	1516 U	1085	1516 T	1517	1517	1517
95	1069 T	1069 T	1069 T	1085	1085	1085	1085	1517	1517	1517
100	1069 T	1069 T	1085	1085	1085	1069	1069	1517	1517	1517
105	1069 T	1085	1085	1085	1069	1069	1085 H	1516 K	1517	1517
110	1069	1069	1069	1069	1085 H	1085 H	928 T	928 T	928	928
115	1069	1069	1069	1069	1085 H	1085 H	928 T	928 T	928	928
120	1069	1069	1069	928 T	928 T	928 T	928 T	928	928	1926K
125	1069	1086 U	1086 U	928 T	928 T	928 T	928 T	928	1926K	1926K
130	1086 U	1086 U	928 T	928 T	928 T	928	928	928	1926K	1926K
135	1086 U	1086 U	928 T	928 T	928	1086 T	1086 T	1086	1926K	1926K
140	1086 U	928 T	928	928	1086 T	1086 T	1086 T	1086	1926K	1086H
145	928 T	928	1086 T	1086 T	1086 T	1086	1086	1086	1086H	1086H
150	1320 T	1086 T	1086 T	1086 T	1086	1086	1086 H	1086 H	1086H	1086H
155	1320 T	1086 T	1086 T	1086	1086	1086	1086 H	1086 H	1086H	1086H
160	1320 T	1086 T	1086	1320	1320	1086 H	1086 H	1086 H	1086H	1320H
165	1320 K	1320 K	1320 K	1320	1320	1086 H	1086 H	1086 H	1320H	1320H
170	1320 K	1320 K	1320	1320	1320	1086 H	1086 H	1086 H	1320H	1934
175	1320 K	1086	1086	1086 H	1086 H	1086 H	1086 H	1086 H	1934	1935
180	1320 K	1320	1320	1320	1320	1086 H	1086 H	1086 H	1935	1935
185	1320 K	1320	1320	1086 H	1086 H	1086 H	1320 H	1320 H	1936	1936
190	1320	1320	1320	1086 H	1086 H	1320H	1320 H	1320 H	1936	1847
195	1320	1320	1320	1086 H	1086 H	1320 H	1320 H	1320 H	1847	1847
200	1320	1846 T	1320 H	1320 H	1320 H	1320 H	1320 H	1320 H	1847	1847
210	1320	1320 H	1320 H	1320 H	1320 H	1846	1846	1847	1847	1848
220	1846 T	1320 H	1320 H	1320 H	1846	1846	1846	1847	1848	1848
230	1320 H	1846	1846	1846	1846	1847	1847	1847	1848	1848
240	1320 H	1846	1846	1846	1847	1847	1847	1848	1848	—
250	1846	1847	1847	1847	1847	1848	1848	1848	—	—
260	1847	1847	1847	1847	1848	1848	1848	—	—	—
270	1847	1847	1848	1848	1848	1848	—	—	—	—
280	1848	1848	1848	1848	1848	—	—	—	—	—
300	1848	1848	1848	1848	—	—	—	—	—	—

Version: 1.10.2009

Als Grundlage für die Berechnung obiger Auswahltabelle dienen normale Ansaugbedingungen für den Lüfter. Wird die Luft über ein Sonnendach oder durch einen Wärmetauscher angesogen, muss die Stockhöhe als mindestens 0,5 m höher angenommen werden.

Die Lüfter sind mit entsprechenden FAT-Test-Nummern bezeichnet.

Wir stellen auch Ventilatoren nach kundenspezifischen Wünschen her. Fragen Sie uns.